

LOGICOM

REPAIR MANUAL/MANUEL DE RÉPARATION

ORION E1 & ORION E1 Plus

ID Picture/ Photo d'identité



LOGICOM

Route Map / Carte routière

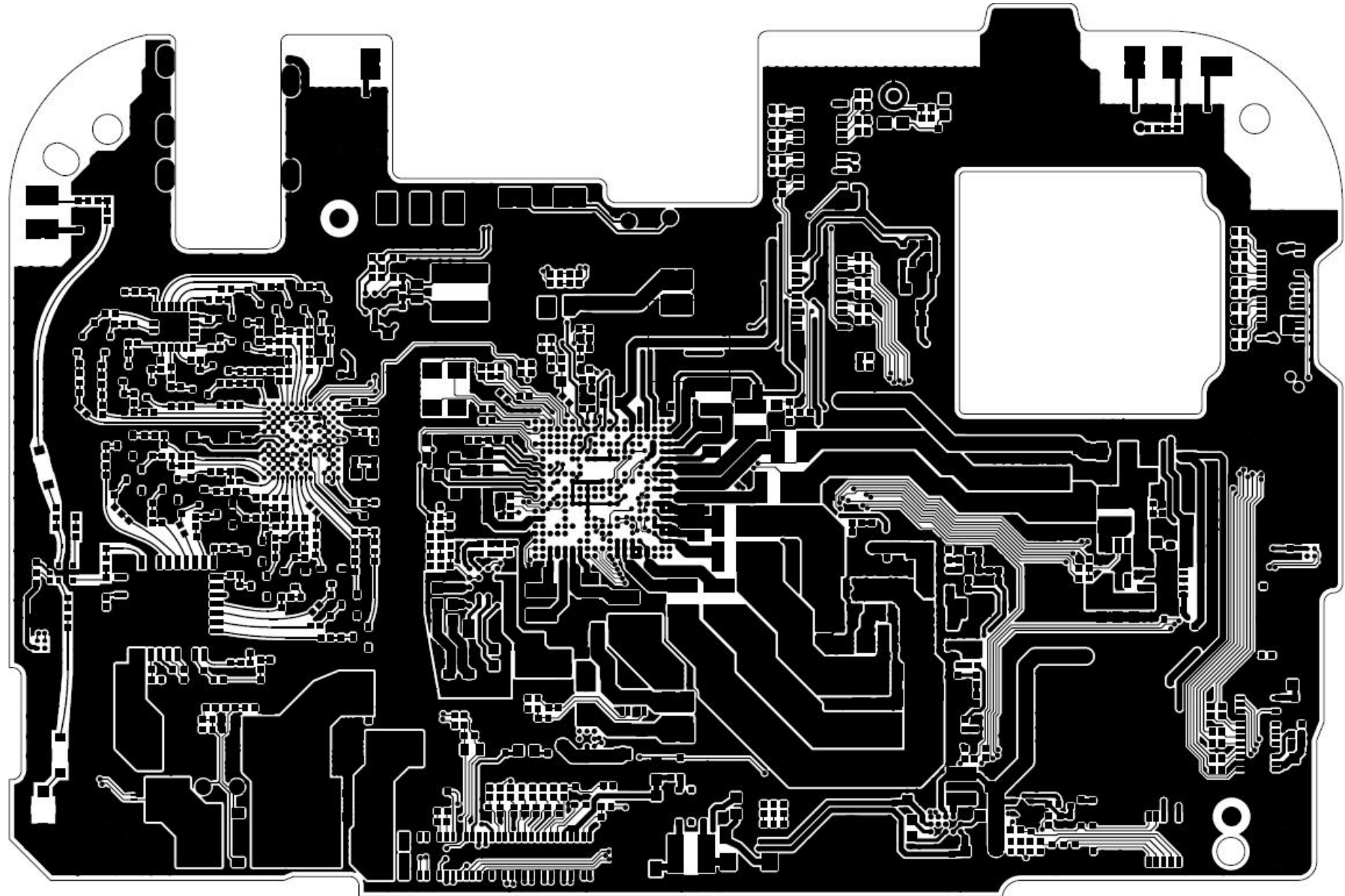

LOGICOM

Route Map / Carte routière

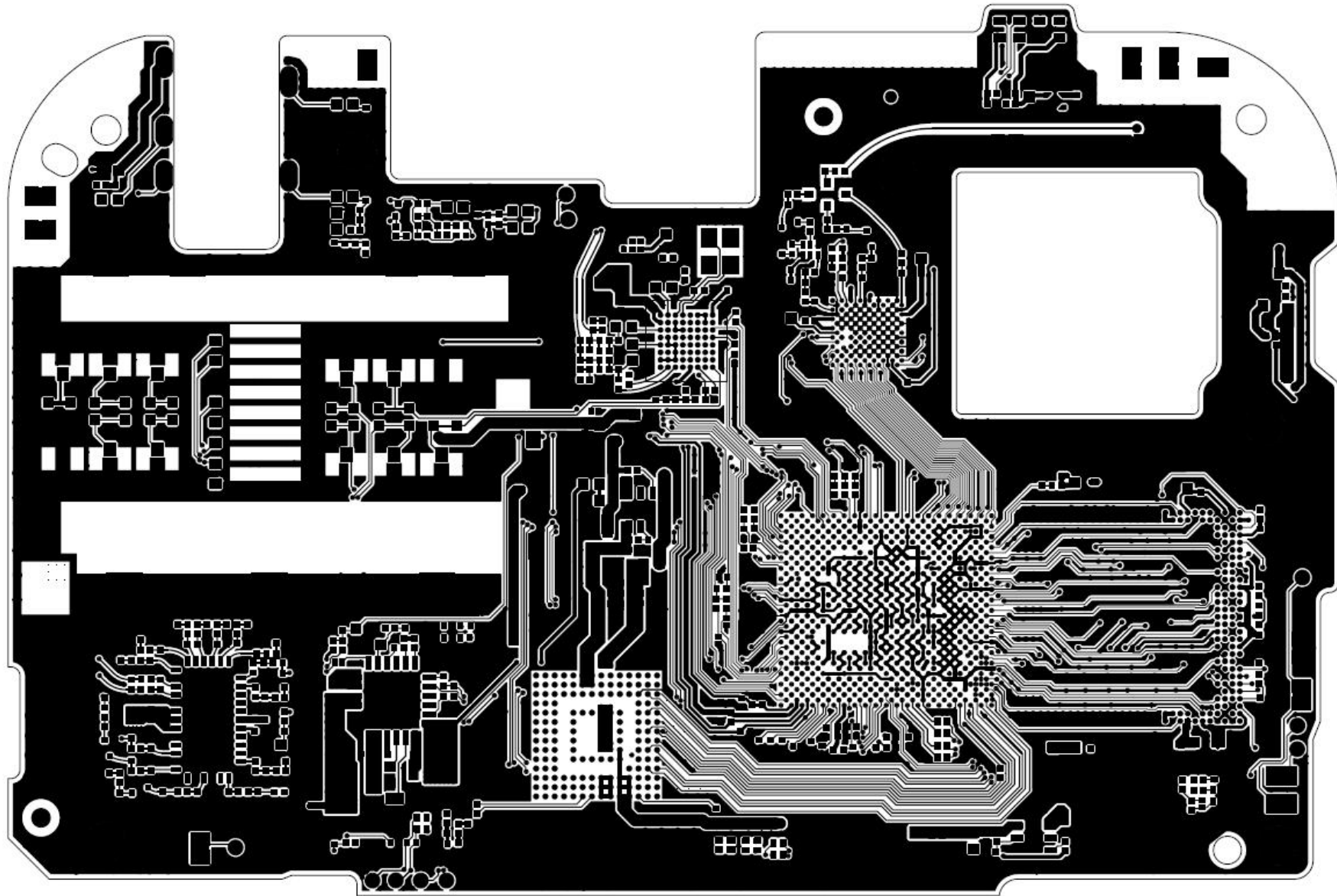



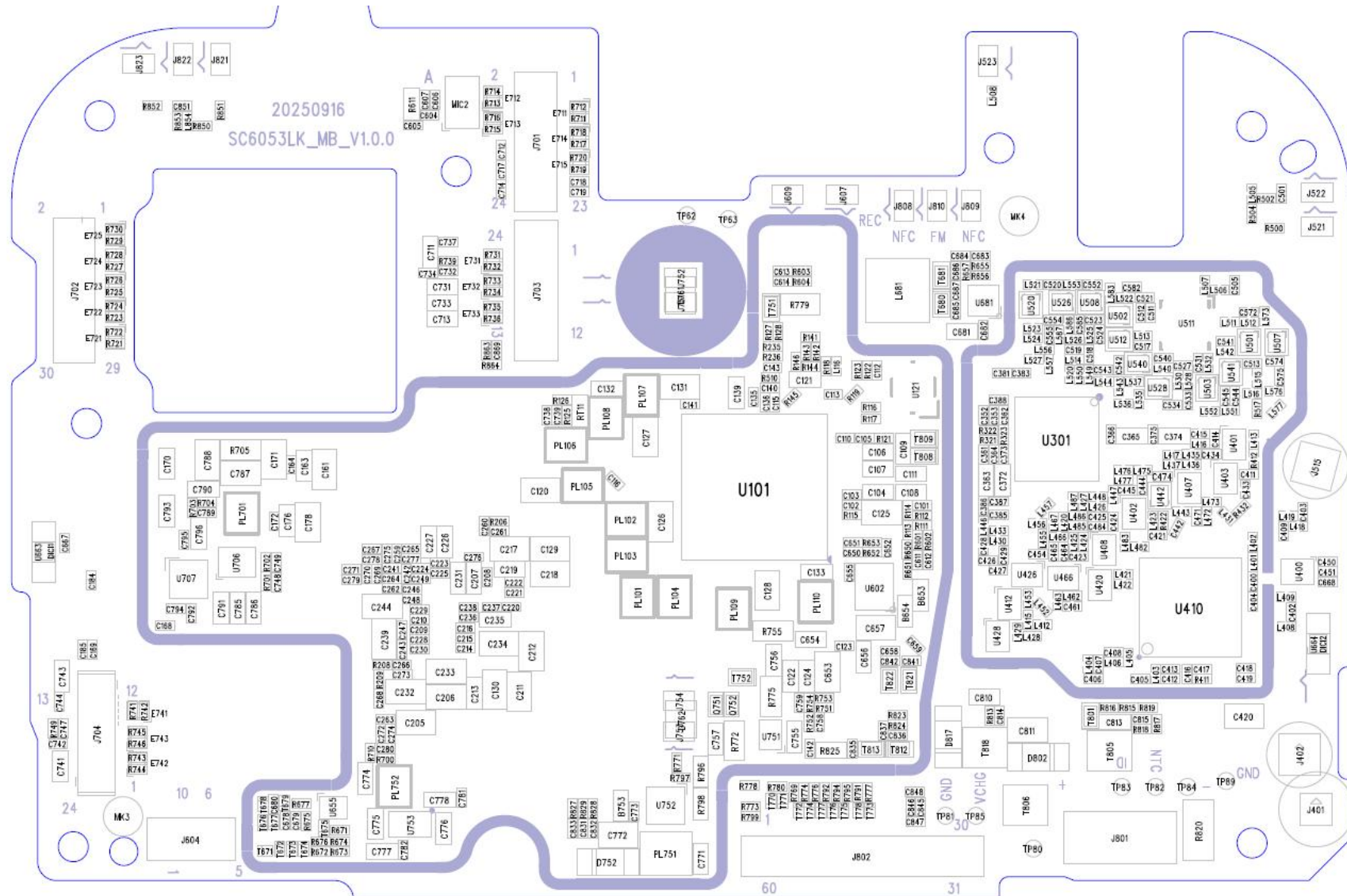



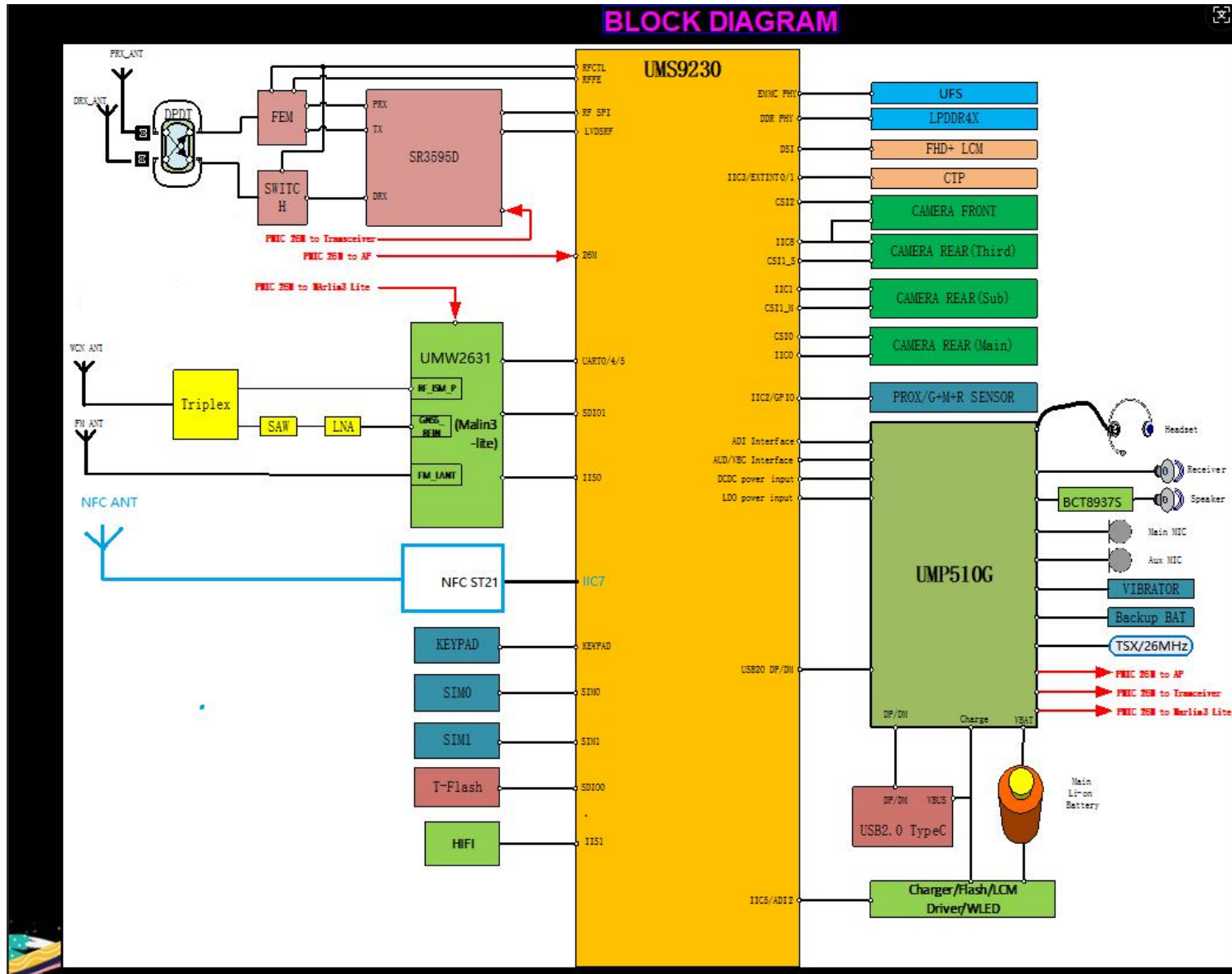



Route Map / Carte routière



Block diagram/ Diagramme fonctionnel



Tools to be prepared / Outils nécessaires

| schematic diagram for repair | | | | | |
|------------------------------|---|---------------------------|---|-------------------|---|
| Name | schematic diagram | Name | schematic diagram | Name | schematic diagram |
| Plastic crowbar |  | Disassembly piece |  | sucker |  |
| cross-head screwdriver |  | Brush |  | Anhydrous Alcohol |  |
| Soldering Iron |  | Heat Gun |  | magnifying glass |  |
| Multimeter |  | DC regulated power supply |  | | |

Precautions / Précautions

Maintenance Precautions

Disconnect Power First: Remove the battery or disconnect the power flex cable when accessible. If inaccessible, take measures to minimize voltage hazards.



ESD Protection: Wear an ESD wrist strap and ensure proper grounding; use an anti-static mat on the work surface.

Screw Management: Keep screws organized by area (take photos + use separate compartments). Mixing screws of different lengths can damage the motherboard.

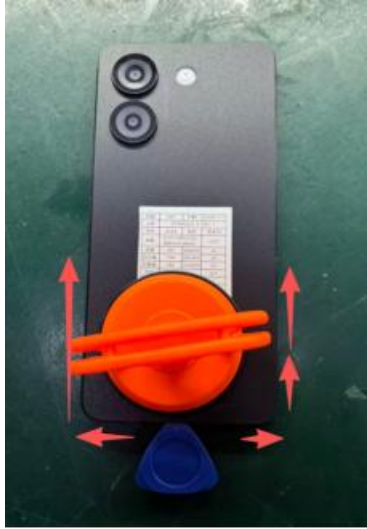

Do not use metal tweezers to handle the battery: the internal component is lithium, and puncturing the membrane with metal can cause a fire or explosion."

Do not short the red and black leads while measuring voltage, as this will damage the motherboard components.

STEP 1: Disassembly battery cover

| Operating steps | | Operation diagram and instructions | |
|-----------------------------|---|---|---|
| Operating Content | <p>1. use a Opening tools of Plastic sheet to separate the bottom of the battery cover and pull it upward to separate the battery cover and the phone middle frame, ensuring the opening tool can be inserted into the gap. (See Diagram 1)</p> <p>2. Insert the opening tool of Plastic sheet into the gap between the battery cover and the phone frame, and separate the adhesive of the battery cover from the phone frame in the direction of the arrow. Finally, remove the battery cover completely. (See Diagram 2)</p> <p>3. After the battery cover is removed, proceed to the next disassembly step.</p> | <p>Diagram 1</p>  | <p>Diagram 2</p>  |
| Quality Control Point (QCP) | <p>Plastic opening tools must be used to prevent the phone from being scratched.</p> | | |

STEP 2: disassembly screw

| Operating steps | | illustration diagram and instructions | |
|------------------------------------|---|--|--|
| <p>Operating Content</p> | <ol style="list-style-type: none"> 1.Prepare a screwdriver and remove all 15 screws marked in the red circles as shown in Diagram 1 2.Use a SIM ejector tool to remove the SIM card tray as shown in Diagram 2. 3.After removing the screws, proceed to the next disassembly step. | <p style="text-align: center;">Diagram 1</p>  | <p style="text-align: center;">Diagram 2</p>  |
| <p>Quality Control Point (QCP)</p> | <p>The screwdriver bit should be a PH0 type with a cutting edge diameter of approximately 3mm.</p> | | |

STEP 3: disassembly middle cover

| Operating steps | | illustration diagram and instructions | |
|-----------------------------|---|---|---|
| Operating Content | <p>1.Prepare an opening tool, insert it into the gap between the USB interface and the midframe, then separate the front cover from the midframe by sliding along the arrow's direction (as shown in Diagram 1).</p> <p>2.After removing the midframe(as shown in Diagram 2), proceed to the next disassembly step.</p> | <p>Diagram 1</p>  | <p>Diagram 2</p>  |
| Quality Control Point (QCP) | | | |



STEP 4: disassembly FPC

| Operating steps | | illustration diagram and instructions | |
|------------------------------------|---|--|--|
| <p>Operating Content</p> | <p>According to the sequence marked in the image, use the opening tool to remove the battery FPC, camera FPC, and display FPC one by one.</p> |  | |
| <p>Quality Control Point (QCP)</p> | <p>The FPC on the battery connector must be removed first, followed by the FPC cables of the camera and display.</p> | | |



STEP 5: disassembly mainboard

| Operating steps | | illustration diagram and instructions |
|-----------------------------|---|--|
| Operating Content | According to the arrow position marked in the image, use a pry tool to lift the motherboard to an 80-degree angle and then remove it from the front casing. |  |
| Quality Control Point (QCP) | | |



STEP 6: disassembly Sub-board

| Operating steps | | illustration diagram and instructions | |
|-----------------------------|--|---|---|
| Operating Content | <p>1.Remove the coaxial cable and display FPC cable in sequence at the positions marked 1 and 2 in the diagram.</p> <p>2.Detach the Sub-board from the front casing and remove the USB dust cover.</p> | <p>Diagram 1</p>  | <p>Diagram 2</p>  |
| Quality Control Point (QCP) | | | |

STEP 7: disassembly battery

| Operating steps | | illustration diagram and instructions | |
|-----------------------------|--|---|---|
| Operating Content | <ol style="list-style-type: none"> 1. Tear off the pull tabs on both ends of the battery. 2. After removing the pull tabs, take the battery out. | <p>Diagram 1</p>  | <p>Diagram 2</p>  |
| Quality Control Point (QCP) | | | |

STEP 8: disassembly motor and receiver

| Operating steps | | illustration diagram and instructions | |
|-----------------------------|--|---|--|
| Operating Content | <ol style="list-style-type: none">1. Use metal tweezers to remove the motor.2. Use Disassembly stick to remove the receiver. | <p>Motor</p>  | <p>Receiver</p>  |
| Quality Control Point (QCP) | <p>The action of removal will only be performed if it is confirmed that the motor/receiver needs to be replaced; otherwise, there is no need to remove them.</p> | | |





Components List / Liste des composants



Item Component name

- 1. main board
- 2. back housing
- 3. sub board
- 4. back main camera
- 5. front camera
- 6. back sub camera
- 7. Multi-band Antenna
- 8. front camera sleeve
- 9. usb sleeve
- 10.earphone jacket sleeve
- 11.mian camera sleeve
- 12. SIM card tray
- 13.side key FPC
- 14.side key
- 15. main Antenna
- 16.WiFi BT antenna
- 17.back sub camera lens
- 18.screw
- 19.receiver
- 20.front housing
- 21.speaker
- 22.motor
- 23.screen
- 24.back housing
- 25.battery





Components List / Liste des composants

| item | Item Component name (EN) | Nom du composant (FR) | Picture | illustrate |
|------|------------------------------|----------------------------------|---|--|
| 1 | Back cover | Coque arrière |  | |
| 2 | PCBA Bracket | Support PCBA |  | There is no PCBA bracket; the PCBA is supported by the front cover. |
| 3 | Back housing waterproof part | Pièce étanche du boîtier arrière |  | The back housing waterproofing is achieved by the battery cover foam |
| 4 | Front housing | Boîtier avant |  | |
| 5 | Back housing | Boîtier arrière |  | |

Components List / Liste des composants

| | | | | |
|----|---------------------|-----------------------|---|---|
| 6 | USB waterproof plug | Bouchon étanche USB |  | |
| 7 | LTE antenna bracket | Support d'antenne LTE |  | There is no antenna bracket; the antenna is secured to the back housing |
| 8 | DOME | Dôme |  | The DOME is located on the side key FPC |
| 9 | Rear Camera | Caméra arrière |  | |
| 10 | Motor | Moteur |  | |

Components List / Liste des composants

| | | | | |
|----|----------------|---------------------------|--|--|
| 11 | Mic | Micro |  | The microphone is located on the sub board |
| 12 | Speaker | Haut-parleur |  | |
| 13 | Receiver | Écouteur |  | |
| 14 | Buttons | Boutons |  | |
| 15 | Metal side bar | Barre latérale métallique | | there is no Metal side bar |





Components List / Liste des composants

| | | | | |
|----|-----------------------|-------------------------------------|---|---|
| 16 | Corner cover | Cache d'angle | | there is no Corner cover |
| 17 | PCBA conductive cloth | Tissu conducteur PCBA |  | The PCBA conductive cloth is located on the front cover |
| 18 | Speaker cavity foam | Mousse de la cavité du haut-parleur |  | The Speaker cavity foam is fixed ed on the Speaker |
| 19 | LCD IC support foam | Mousse de support IC LCD | | There is no LCD IC support foam |
| 20 | PCBA | PCBA |  | |

Components List / Liste des composants

| | | | | |
|----|----------------|-----------------------|---|--------------------------------|
| 21 | LCD | LCD |  | |
| 22 | LED | LED |  | The LED is located on the PCBA |
| 23 | Bluetooth line | Câble Bluetooth | | There is no Bluetooth line |
| 24 | Camera lens | Lentille de la caméra |  | |
| 25 | LED lens | Lentille LED |  | |

Components List / Liste des composants

| | | | | |
|----|--------------------------------|---|---|--|
| 26 | Main lens | Lentille principale |  | |
| 27 | Side strip pin conductive foam | Mousse conductrice pour pin de bande latérale | | There is no Side strip pin conductive foam |
| 28 | Chamfered screw | Vis chanfreinée |  | |
| 29 | Side pin | Goupille latérale |  | |
| 30 | Antenna / PCBA bracket screw | Vis du support d'antenne / PCBA |  | |

Components List / Liste des composants

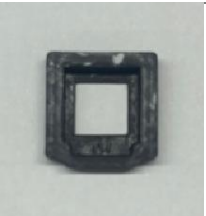
| | | | | |
|----|--------------------------------|---|--|--|
| 31 | Metal side bar screw | Vis de la barre latérale métallique | | There is no Metal side bar screw |
| 32 | Back cover screw | Vis du couvercle arrière |  | |
| 33 | LCD pressing foam | Mousse de maintien LCD | | There is no LCD pressing foam |
| 34 | Camera pad insulation adhesive | Colle isolante pour pastilles de caméra |  | There is no Camera pad insulation adhesive. The insulation adhesive is achieved by the Silicone cover. |

Fault Diagnosis / Reset Steps

Étapes de diagnostic des pannes / de réinitialisation

Common Fault Diagnosis and Repair Guide (Fault → Troubleshooting → Resolution)

Power-on Failure

| Troubleshooting | Resolution |
|--|--|
| Check the charging cable, charging head, and power outlet. | Test with a different cable, adapter, and power outlet. |
| Check if the buttons are functional. | Connect the charger and charge for 15 to 20 minutes. |
| No response when the power button is pressed. | Restart steps 1. Press and hold the Power button (on the right or top of the phone) for 10–15 seconds. 2. The power menu pops up on the screen; tap Restart. 3. The phone will shut down and boot up automatically to finish restarting. |
| Check if there is any response when charging. | Perform a forced restart (Press and hold the Power button for 20 seconds). |
| Check the battery voltage; it should remain between 3.7V and 4.35V. If the voltage is below 3.3V, the battery is likely damaged. | Replace the battery. |
| Check the battery flex cable and the screen flex cable. | Re-seat all connectors (Many non-boot issues are simply due to loose cables). Inspect the flex cables for breaks or creases. |
| Check the motherboard for water damage, corrosion, or burn marks. | For water-damaged devices, prioritize cleaning the motherboard (using anhydrous alcohol + a brush). |
| Check motherboard current: 0mA (completely unresponsive). | Replace faulty flex cables, the power button, or the motherboard. |
| Check motherboard current: fluctuating between 0-50mA. | Replace the motherboard Power IC, CPU, or (RAM). |
| Check motherboard current: rises to 100–150mA and then stops. | |
| Check motherboard current: above 1A (short circuit on the motherboard). | In case of motherboard short circuit, cut the power immediately. Attempt to replace the Power IC, Audio IC, Display Power Supply MOSFET, or filter capacitors. |

Fault Diagnosis / Reset Steps

Étapes de diagnostic des pannes / de réinitialisation

| Screen Failure | |
|--|---|
| Troubleshooting | Resolution |
| The phone vibrates or makes sounds when turned on, but the screen remains black. | Restart steps 1. Press and hold the Power button (on the right or top of the phone) for 10–15seconds. 2. The power menu pops up on the screen; tap Restart. 3. The phone will shut down and boot up automatically to finish restarting. |
| | Re-download the mobile phone system software |
| Loose flex cable | Reconnect the flex cable (unplug and plug it back in). |
| Damaged flex cable | Replace the damaged screen flex cable. |
| screen is cracked, has liquid leakage, or is flickering. | Open the phone and replace the screen assembly. |
| The phone is on, but the screen is not displaying anything. | If the backlight is damaged, you need to open the phone and replace the screen assembly. |

Fault Diagnosis / Reset Steps

Étapes de diagnostic des pannes / de réinitialisation

| No charging or slow charging Failure | |
|---|---|
| Troubleshooting | Resolution |
| Check if the Type-C charging port is clogged with dust, exposed to water, or oxidized | Clean the phone's Type-C charging port with a soft brush and a small amount of anhydrous alcohol (power off first). |
| Check if the Type-C charging cable and charger are functioning properly | Replace the Type-C charging cable or charger. |
| Check if the flex cables on the mainboard and sub-board are loose, and if the solder joints have cold solder (or dry joints). | Reconnect the flex cables on the motherboard and sub-board (re-seat), or replace the flex cables. |
| Check that the battery voltage remains between 3.7V and 4.35V. If the voltage is below 3.3V, the battery is likely damaged." | Replace the battery. |
| The charging IC (Power Management IC / PMIC) or the charging protection MOSFET on the motherboard is damaged. | Replace the charging IC |
| | Replace the charging protection MOSFET |
| | Replace the motherboard assembly |

Fault Diagnosis / Reset Steps

Étapes de diagnostic des pannes / de réinitialisation

| No communication signal; unable to make calls or weak signal Failure. | |
|---|---|
| Troubleshooting | Resolution |
| The phone is re-searching for signal. | Turn on Airplane Mode for 5 seconds, then turn it off again. |
| Restart the phone. | <p style="text-align: center;">Restart steps</p> 1. Press and hold the Power button (on the right or top of the phone) for 10–15 seconds. 2. The power menu pops up on the screen; tap Restart. 3. The phone will shut down and boot up automatically to finish restarting. |
| Check if there is an outstanding balance or if the service is restricted by the carrier. | Call the carrier's customer service to confirm. |
| Check network settings. | step: Settings → System → Reset → Reset Network Settings. |
| SIM card is damaged. | Replace the SIM card. |
| Check if the SIM card or SIM card slot is oxidized | Clean the SIM card and SIM tray with a soft brush and a small amount of anhydrous alcohol (while powered off). |
| Disassemble the phone to check if the antenna clip is loose or if the antenna contact pins are deformed. | Reconnect the antenna connector, or repair and replace the antenna shrapnel. |
| Disassemble the phone to inspect if the antenna FPC (Flexible Printed Circuit) attached to the middle frame is damaged. | Replace the antenna FPC (Flexible Printed Circuit). |
| Damage to the baseband power IC or RF (Radio Frequency) IC on the motherboard. | Replace the baseband power IC and RF IC. |
| Motherboard components are damaged. | Replace the motherboard components. |
| System file damage causing signal loss. | Re-download the phone's system software. |

Fault Diagnosis / Reset Steps

Étapes de diagnostic des pannes / de réinitialisation

| camera Failure | |
|--|--|
| Troubleshooting | Resolution |
| A frozen camera app or insufficient system resources can cause the camera to fail to open. | <p style="text-align: center;">Restart steps</p> <ol style="list-style-type: none"> 1. Press and hold the Power button (on the right or top of the phone) for 10–15seconds. 2. The power menu pops up on the screen; tap Restart. 3. The phone will shut down and boot up automatically to finish restarting. |
| Clear the camera app cache. | Step: Settings → Apps → Camera → Storage → Clear Cache |
| Check camera permissions. | Step: Settings → Apps → Camera → Permissions → Enable "Camera Access" / "Camera Permission" |
| The camera screen is black, but an error message appears saying "Camera is occupied" or "Can't connect to the camera." | Restart the phone or disassemble it to re-seat the camera flex cable. |
| Neither the front nor the rear camera is working. | Replace the camera module |
| Damage to the camera power IC on the motherboard. | Replace the camera power IC on the motherboard |
| Damage to the CPU on the motherboard. | Replace the CPU on the motherboard |
| Damage to the motherboard components. | Replace the motherboard components |

Fault Diagnosis / Reset Steps

Étapes de diagnostic des pannes / de réinitialisation

| audio Failure | |
|---|--|
| Troubleshooting | Resolution |
| Check Mute Mode | Turn off the silent mode switch |
| System lag/freezing may cause the speaker or earpiece to be silent. | Restart steps 1.Press and hold the Power button (on the right or top of the phone) for 10–15seconds. 2.The power menu pops up on the screen; tap Restart. 3.The phone will shut down and boot up automatically to finish restarting. |
| Check if a Bluetooth device is connected. | Turn off Bluetooth |
| Speaker has low volume, noise, or distortion. | Replace the speaker |
| Earpiece has low volume, noise, or distortion. | Replace the receiver |
| Microphone is not functioning. | Replace the microphone on the motherboard or replace the motherboard assembly |
| Audio IC issue on the motherboard. | Replace the audio codec IC |
| Motherboard component issue. | Replace the motherboard assembly |

Fault Diagnosis / Reset Steps

Étapes de diagnostic des pannes / de réinitialisation

| WiFi and Bluetooth failure | |
|--|---|
| Troubleshooting | Resolution |
| System freezes can prevent WiFi and Bluetooth from turning on. | <p>Restart steps</p> <ol style="list-style-type: none"> 1.Press and hold the Power button (on the right or top of the phone) for 10–15seconds. 2.The power menu pops up on the screen; tap Restart. 3.The phone will shut down and boot up automatically to finish restarting. |
| Check the WiFi/Bluetooth toggle. | Step: Power On → Power Off → Power On again to allow the module to re-initialize. |
| Reset network settings. | Step: Settings → System → Reset → Reset Network Settings. |
| System bugs can cause abnormalities in the WiFi and Bluetooth modules. | Update System |
| Check if the WiFi/Bluetooth MAC address is available. | Step: Settings → About Phone → WiFi / Bluetooth MAC Address. |
| Antenna damage or poor connection. | Disassemble the phone to replace the Antenna FPC or replace the motherboard pogo pins. |
| WiFi/Bluetooth module damage. | Replace the WiFi/BT Chip on the motherboard. |

Required Information/ Informations requises

| INFORMATION REQUIREMENTS | |
|---|--|
| From 20 June 2025: | Based on actual product |
| Manufacturers, importers or authorised representatives shall provide in the technical documentation and make publicly available on free access websites of the manufacturer, importer or authorised representative the following information: | The device is compatible with FAT12/16, FAT32, and extra FAT file systems. While the official specification supports a maximum 128GB storage card, 256GB and 512GB cards are theoretically supported |
| compatibility with removable memory cards, if any | not available |
| indicative weight range of the following critical raw materials and environmentally relevant materials: | The machine's inherent tolerance is around $\pm 5g$. |
| cobalt in the battery (weight range: less than 2 g, between 2 g and 5 g, above 5 g) | >5g |
| tantalum in capacitors (weight range: less than 0,05 g, between 0,05 g and 0,2 g, above 0,2 g) | 0.05g~0.2g |
| neodymium in loud speakers, vibration motors, and other magnets (weight range: less than 0,05 g, between 0,05 g and 0,2 g, above 0,2 g) | >0.2g |
| gold in all components (weight range: less than 0,02 g, between 0,02 g and 0,1 g, above 0,1 g). | >0.1g |
| the indicative value of the recyclability rate R _{cyc} | not available |
| the indicative percentage of recycled content for the product or a part thereof, where available; if not available, the recycled content should be indicated as "not known" or "not available" | not available |

Required Information/ Informations requises

| | |
|--|--|
| Ingress protection rating | IP44 |
| Minimum battery endurance in cycles in number of cycles | Rated Battery Capacity: 5000 mAh |
| | Cycle : 1000 cycles |
| In case of foldable devices, it shall be indicated that “This device did not undergo a scratch resistance test”. | N/A |
| Manufacturers, importers or authorised representatives shall provide user instructions in the form of a user manual on a free access website of the manufacturer, importer or authorised representative. Those instructions shall include instructions for battery maintenance, including the following: | N/A |
| Impacts on battery lifetime related to exposure of the device to elevated temperatures, suboptimal charging patterns, fast charging and other known adverse factors | <ul style="list-style-type: none"> · High temperatures accelerate the decomposition and evaporation of the electrolyte within the battery and exacerbate side reactions in the cathode and anode materials, leading to a permanent increase in internal resistance and a permanent loss of capacity. · Fast charging is inherently safe, but high currents generate more heat and place greater stress on the lithium-ion intercalation/deintercalation process within the battery, which slightly accelerates aging over the long term. Charging at fast speeds in high-temperature environments is particularly damaging, effectively doubling the harm. |

Required Information/ Informations requises

| | |
|---|--|
| <p>effects of switching off radio connections, such as WiFi, Bluetooth, on power consumption</p> | <ul style="list-style-type: none">· When 2.3.4.G mode is disabled, the standby current of the mobile phone can be reduced from 1–5 mA to 0.1–0.5 mA. The main consumption comes from the sleep state of the baseband processor and minimal background system activities. Disabling Wi-Fi, especially turning off advanced options such as "Scanning always available," can eliminate the power consumption caused by these periodic wake-ups.· Simply turning off Bluetooth offers a nearly negligible improvement in pure standby battery life (potentially less than 1%). |
| <p>information about whether the device supports other features, which extend battery lifetime, such as smart charging and about how these features are activated or under which conditions they work best.</p> | <p>not available</p> |
| <p>Where the package does not include a charger, the user instructions referred to in point 2 shall include the following information: "For environmental reasons this package does not include a charger. This device can be powered with most USB power adapters and a cable with USB Type-C plug."</p> | <p>For environmental reasons this package does not include a charger. This device can be powered with most USB power adapters and a cable with USB Type-C plug."</p> |

Thank you ! / Merci !